

A broadband omnidirectional barrel-stave flextensional transducer

D.F. Jones and D.A. Christopher

*Defence Research Establishment Atlantic, P.O. Box 1012, Dartmouth, Nova Scotia, Canada B2Y 3Z7
jones@drea.dnd.ca*

Abstract: The piezoelectric Class III barrel-stave flextensional transducer is an underwater acoustic source that is capable of generating sound over a wide frequency band. This broadband performance is achieved through coupling the fundamental flexural and longitudinal modes of vibration. Near the low frequency flexural resonance, the Class III transducer is small compared to a wavelength, and its radiation is omnidirectional. However, at frequencies in the vicinity of the longitudinal resonance, the radiation is directional. In this article, we show through the use of a finite element model that the Class III transducer can be designed for omnidirectional radiation over the entire band.

PACS numbers: 43.38.Fx, 43.38.Ar

1. Introduction

Barrel-stave flextensional transducers have been classified into three distinct categories based on the shapes of their external radiating staves¹⁻³. The Class I barrel-stave transducer is primarily operated at its low-frequency fundamental flexural mode, which is well separated from modes at higher frequencies. A Class II design can be used to achieve higher acoustic power at the same flexural resonance frequency as its Class I counterpart. This high-power transducer is a modified Class I design that can accommodate a longer driver, which extends beyond the extremities of the curved staves. A Class III design is basically an end-to-end graft of two Class I transducers. This dual-shell design is capable of broadband radiation due to multimode coupling between the fundamental flexural resonance of the staves and the longitudinal resonance of the driver. The Class III transducer is the subject of this article.

Although the Class III barrel-stave flextensional transducer can radiate sound over a wide band, the directional characteristics of the acoustic radiation change with frequency. For those applications that require broadband omnidirectional sources, a common solution is to use spherical transducers. However, the transducer designer may wish to take advantage of a high energy density material like magnetostrictive rare earth Terfenol-D⁴, which is ideal for longitudinal driver elements (e.g., discs and rings) but not easily formed into or driven as hemispherical elements. Thus, it is useful to examine longitudinally-driven transducers with the purpose of extending the omnidirectional frequency band. In this work, finite element analysis techniques were used to investigate the directional characteristics of a Class III barrel-stave flextensional transducer design.

2. Finite element model

The axisymmetric finite element program MAVART was used to analyze a piezoelectric Class III transducer. The geometry of the model is shown in Fig. 1. Two stacks, each consisting of six Navy Type I piezoceramic rings, are used as drivers. Each ring has an outside diameter of 5.06 cm, an inside diameter of 3.94 cm, and a thickness of 1.02 cm. The steel 1020 end and center plates have an outside diameter of 6.96 cm and a thickness of 2.00 cm. The concave aluminum 7075 staves are 4.0 mm thick, and their radius of curvature

(ROC), the key geometrical parameter of interest, is either 20.0 cm or 6.0 cm. The tangential elastic constants for the aluminum stave material are reduced by a factor of 1000 to simulate individual staves mounted on polygonal plates,⁵ or a slotted shell mounted on circular plates.⁶ The transducer was analyzed in a surrounding sphere of seawater.

3. Predicted results

The performance parameters of interest in this study are the transmitting voltage response (TVR) curves in the axial (Z) and radial (R) directions as well as the XZ directivity patterns. The finite element predictions are shown in Figs. 2-5.

When the radius of curvature of the staves was set to 20 cm, the fundamental flexural and longitudinal resonance frequencies obtained from the peaks in Fig. 2 were 2.65 kHz and 6.31 kHz, respectively. A third peak occurs at 9.57 kHz and corresponds to a second flexural resonance. The TVR curves in the axial and radial directions begin to diverge just beyond the 2.65 kHz peak, indicating a departure from omnidirectionality. This can be seen more clearly in Fig. 3, where the predicted XZ directivity pattern at 2.1 kHz is essentially omnidirectional but elongated in the axial direction at 3.9 kHz.

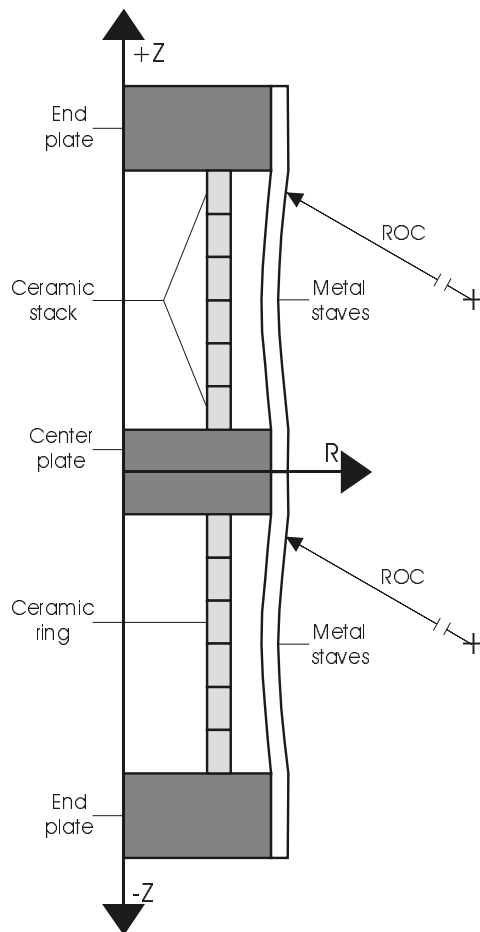

Fig. 1. Class III barrel-stave flextensional transducer geometry.

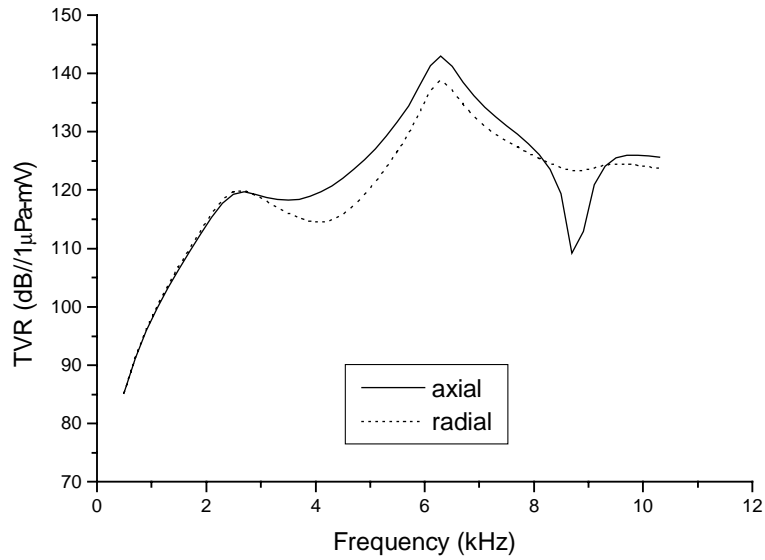

Fig. 2. Predicted TVR curves for the 20 cm ROC configuration.

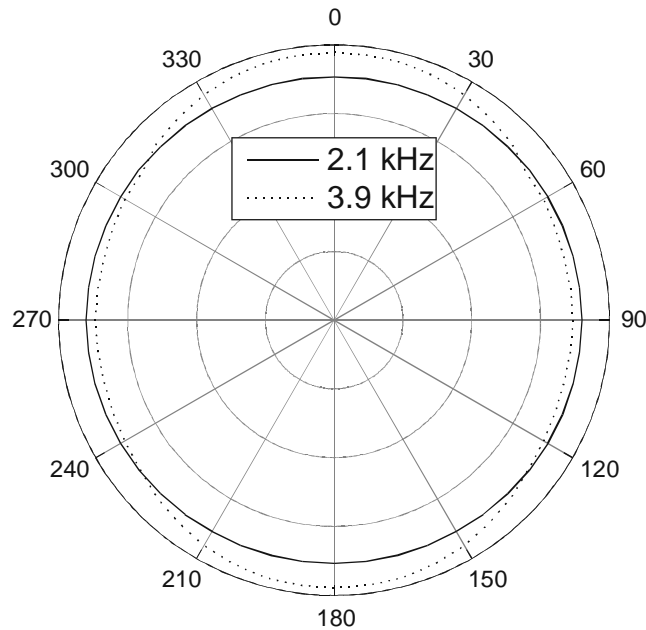

Fig. 3. Predicted XZ directivity patterns for the 20 cm ROC configuration. Center to circumference is 40 dB.

When the radius of curvature of the staves was reduced to 6 cm (i.e., the staves are curved deeper into the transducer), the fundamental flexural resonance increased to 3.98 kHz as shown in Fig. 4. A second flexural resonance is visible at 10.1 kHz, and the longitudinal resonance, which should lie between these flexural modes, does not appear.

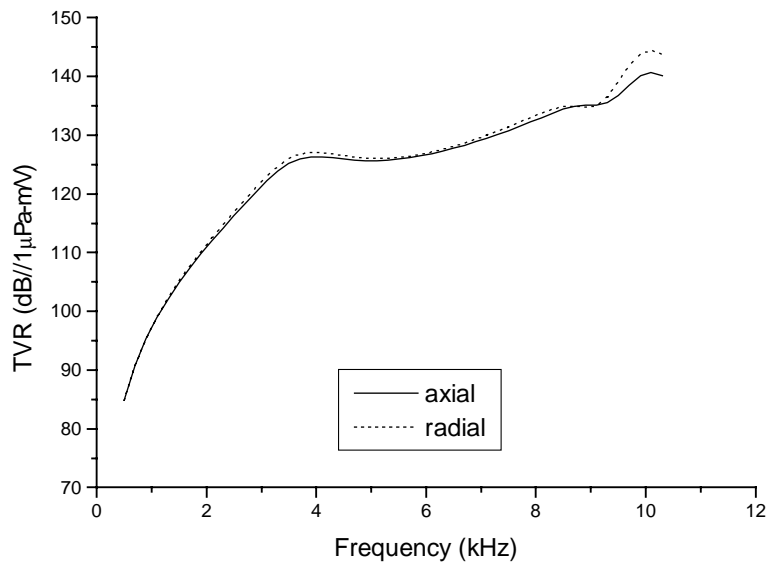

Fig. 4. Predicted TVR curves for the 6 cm ROC configuration.

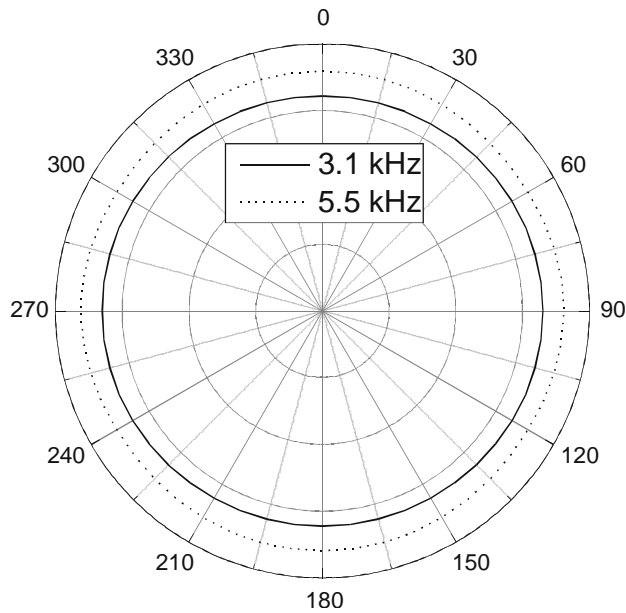

Fig. 5. Predicted XZ directivity patterns for the 6 cm ROC configuration. Center to circumference is 40 dB.

In this case, the axial and radial TVR curves do not significantly deviate from each other over most of the band, indicating omnidirectional radiation extending beyond 8.2 kHz, where the length of the transducer equals a wavelength. Fig. 5 shows two XZ omnidirectional directivity patterns at 3.1 kHz and 5.5 kHz, in agreement with the TVR data.

Two further finite element predictions of note for the 6 cm ROC design concern the electroacoustic efficiency and the directivity index. The former parameter exceeds 65% over the entire 2-9 kHz frequency band, whereas the latter parameter is less than 1.5 dB for all frequencies up to 8.8 kHz.

4. Conclusions

The Class III barrel-stave flextensional transducer has been modelled using finite element analysis techniques. When the concave staves have a shallow curved profile (the 20 cm ROC case), the fundamental flexural mode and the longitudinal mode are clearly evident, and the radiation pattern becomes directional starting at frequencies just above the flexural mode. On the other hand, deeply-curved concave staves (the 6 cm ROC case) cause the fundamental flexural mode to shift to higher frequencies and the longitudinal mode to be suppressed. In addition, the radiation patterns of the deeply-curved design are essentially omnidirectional over the entire 0.5-9 kHz frequency band studied in this work.

References and links

- ¹G.A. Brigham and L.H. Royster, "Present status in the design of flextensional underwater acoustic transducers," *J. Acoust. Soc. Am.* **46**, 92 (abs) (1969).
- ²L.H. Royster, "The flextensional concept: A new approach to the design of underwater acoustic transducers," *Appl. Acoust.* **3**, 117-126 (1970).
- ³D.F. Jones, D.J. Lewis, C.G. Reithmeier, and G.A. Brownell, "Barrel-stave flextensional transducers for sonar applications," DE-Vol. 84-2, in *Proceedings of the 1995 Design Engineering Technical Conferences*, Vol. 3, Part B (American Society of Mechanical Engineers, New York, 1995), pp. 517-524.
- ⁴D.F. Jones and J.F. Lindberg, "Recent transduction developments in Canada and the United States," in *Proceedings of the Institute of Acoustics*, Vol. 17, Part 3 (Institute of Acoustics, St. Albans, U.K., 1995), pp. 15-33.
- ⁵D.F. Jones, "Research and development of the 800 Hz barrel-stave flextensional transducer at the Defence Research Establishment Atlantic," Defence Research Establishment Atlantic Report 98/101, January 1998.
- ⁶D.F. Jones and D.J. Lewis, "The effects of shell wall thickness and number of slots on the performance of the Merchant slotted-shell flextensional projector," Defence Research Establishment Atlantic Technical Memorandum 95/203, February 1995.